

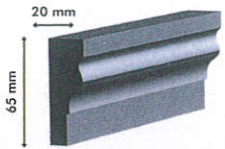

**Greentherm™**  
Architectural Profiles

# Architraves



HPA 001

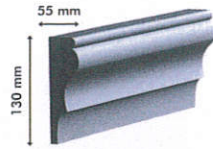

HPA 002

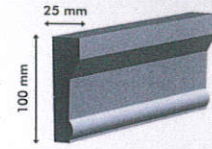

HPA 003

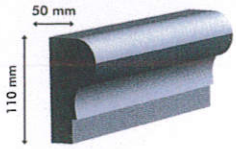

HPA 004

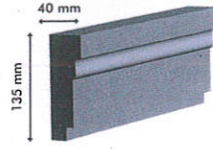

HPA 005

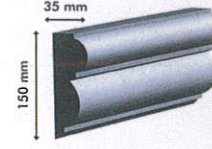

HPA 006

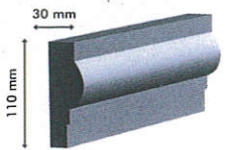

HPA 007

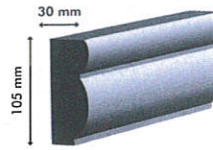

HPA 008

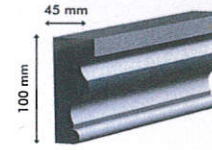

HPA 009



# Bands

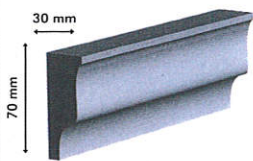

HPB 001

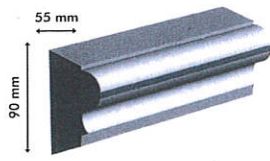

HPB 002

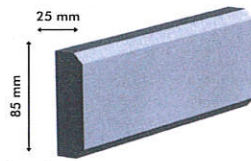

HPB 003

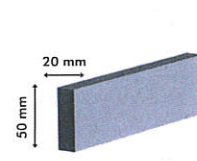

HPB 004

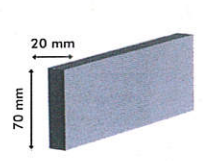

HPB 005

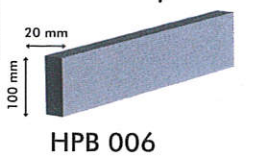

HPB 006

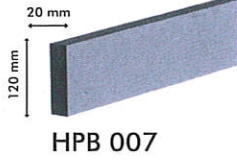

HPB 007

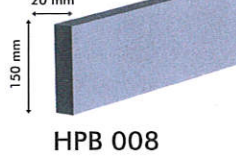

HPB 008



HPB 009

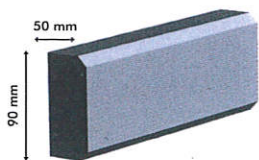

HPB 010

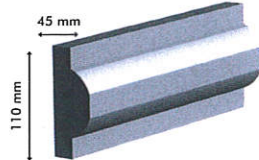

HPB 011

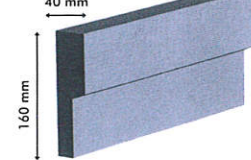

HPB 012

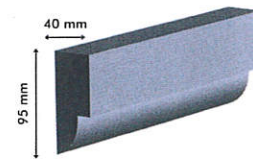

HPB 013

# Parapets

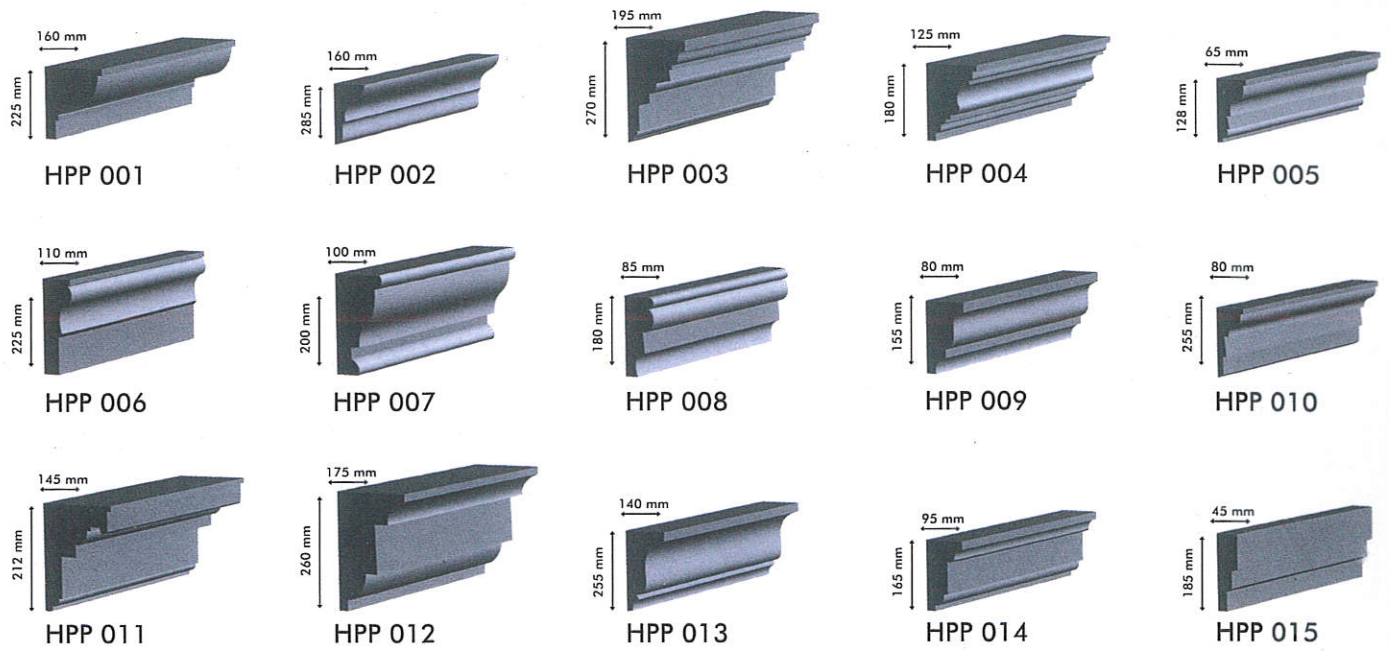

# Chords

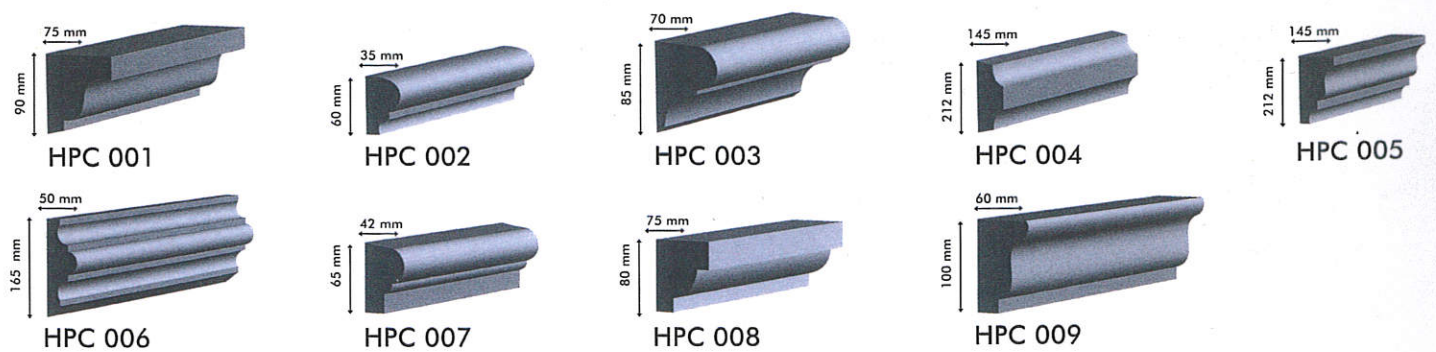

# Overmantles & Sills

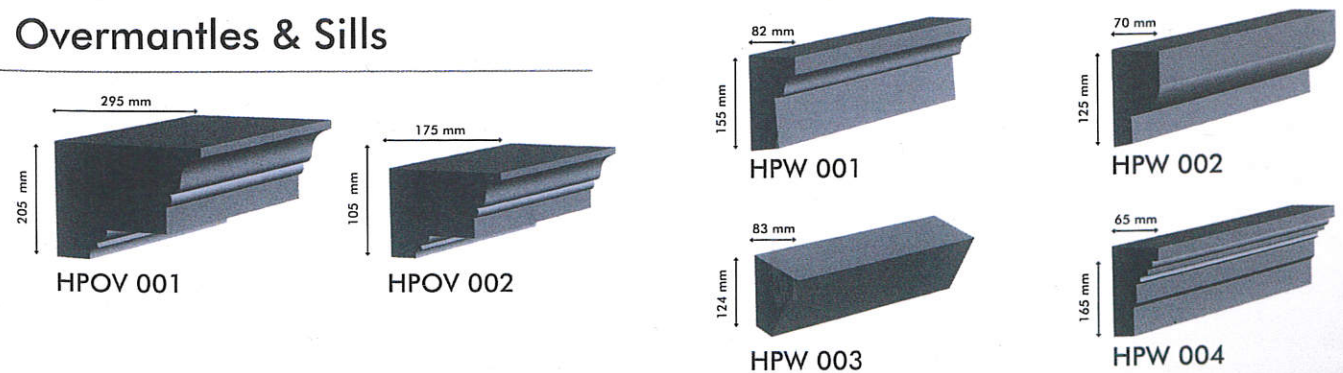

## Columns & Quoins



Decorative Plain Pillar  
HPD 001



Decorative Fluted Pillar  
HPD 002



Decorative Plain Columns  
HPD 003



Decorative Fluted Columns  
HPD 004



Face Quoins  
HPQ 001



Return Quoins  
HPQ 002

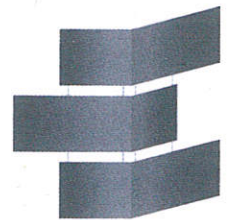

Staggered Quoins  
HPQ 003

## Keystones, Trusses & Motifs

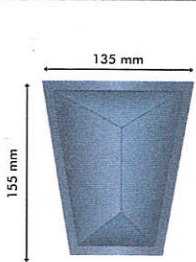

HPK 001

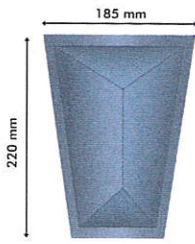

HPK 002

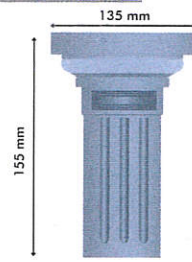

HPT 001

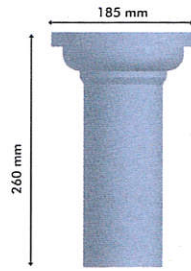

HPT 002

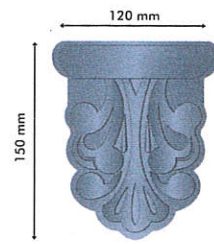

HPM 001

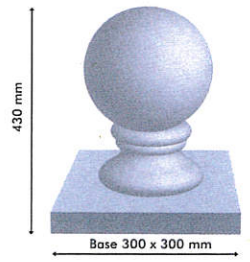

HPBB 001



## Circles

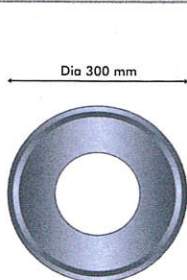

HPCR 001

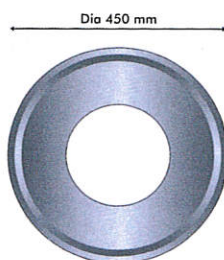

HPCR 002

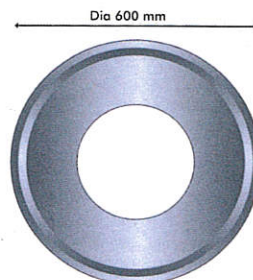

HPCR 003

## Heading

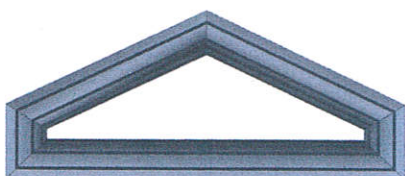

HPH 001

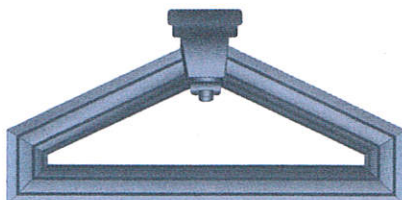

HPH 002



HPH 003

## A stylish range of profiles to suit every facade

Green Product offers a wide range of architectural profiles for both residential and commercial applications. Its superior quality, durability, flexibility, creative and practical solutions to the designer - to give each building its distinctive style.

The profiles are available in different sizes and shapes from straight lengths to arches and curves. The designs complement both the modern and the contemporary thus enabling the preservation of the style, aesthetics and beauty of both classic and modern architecture.

Green Product architectural profiles are manufactured under stringent quality control to ensure a product exclusive in its design, superior in its quality and resistant to UV radiation, rain or any other harsh environment.

### Why Green Product:

**Reliability:** The materials used for our profiles are extremely durable and resistant to environmental influences. It is impact-resistant with an excellent surface texture to ensure reliable coatings on smooth or textured surfaces. These qualities make it a preferred investment for those who seek security and a lasting aesthetic appearance of their homes or buildings.

**Light Weight:** The profiles are crafted from high quality expanded polystyrene foam, which apart from being light in weight enables the profile to be perfectly aligned to any requirements or shape thus giving the designer a free rein in creating and executing solutions.

**Superior Quality:** Our manufacturing process incorporates the use of high quality materials and a superior durable surface. The system consists of a reinforced mesh and an acrylic polymer cement surface which can be painted or textured.

**Versatility:** Light in weight, easily workable and quick to install, Green Product profiles is the delight of any designer. The quality and durability of the materials used ensures technically perfect solutions. Mitre cuts can be produced for perfect fits and a spectrum of designs can be produced ranging from straight to angular and a variety of arches, rustications and supports.

**Durability:** Our profiles are impact-resistant and highly resistant to chemicals, water and other environmental influences.

For further information please contact any Green Product representative in your region.

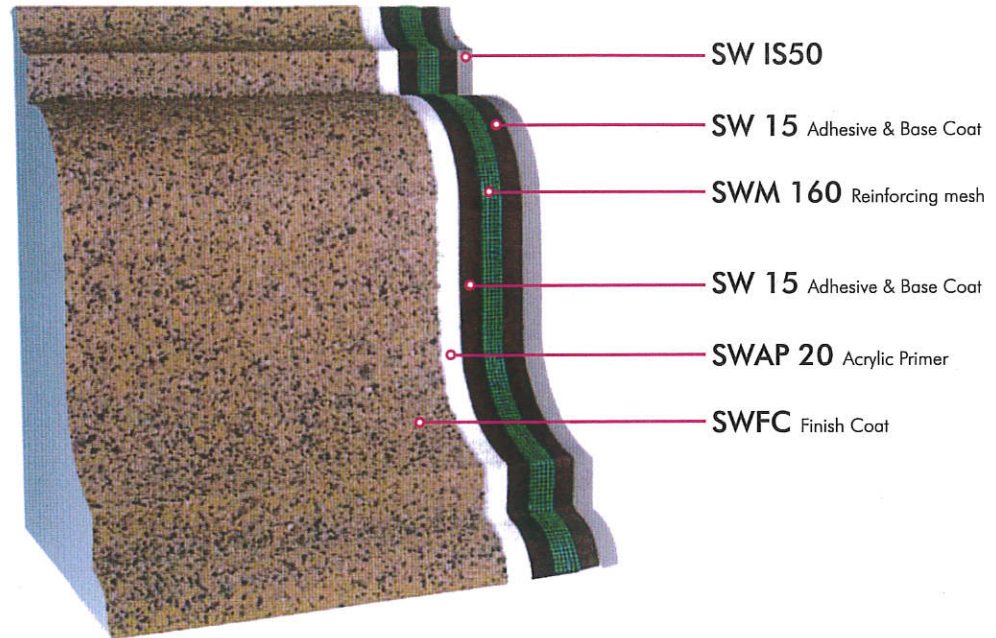

Physical Properties		
Flame Spread Index	ASTM E 84	< 25
Smoke Development	ASTM E 84	<450
Impact Resistance	ASTM D 2794	( 5.7- 10.1)joules
Density	ASTM D 1622	( 35-40)kg/m <sup>3</sup>



Authorized Partner:

**BAS TEC**  
BUILDING A BETTER TOMORROW

P.O. Box 2230-Al Khobar 31952 K.S.A.  
Tel. : +966 13 898 7761  
Fax : +966 13 898 7759

**GREEN PRODUCTS**  
**INDUSTRIES**  
THE BEST A BUILDING CAN GET

GREEN PRODUCTS INDUSTRIES W.L.L.  
C.R. 84884 -1 - P.O Box 10266  
Building No.1923, Road #5146  
Block #951, Askar, Kingdom of Bahrain  
Tel. +973 7737 7707 - Fax +973 7737 7747

E-mail: [gpihb@gpihb.com](mailto:gpihb@gpihb.com) - [www.gpihb.com](http://www.gpihb.com)